



Heavy Construction **ATTACHMENTS**

GEM

LRHC/SRHC

LOADER RAKE/ STACKING RAKE W/CLAMPS

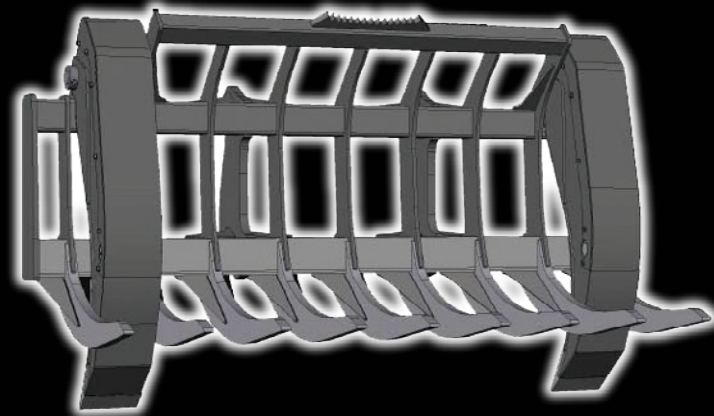
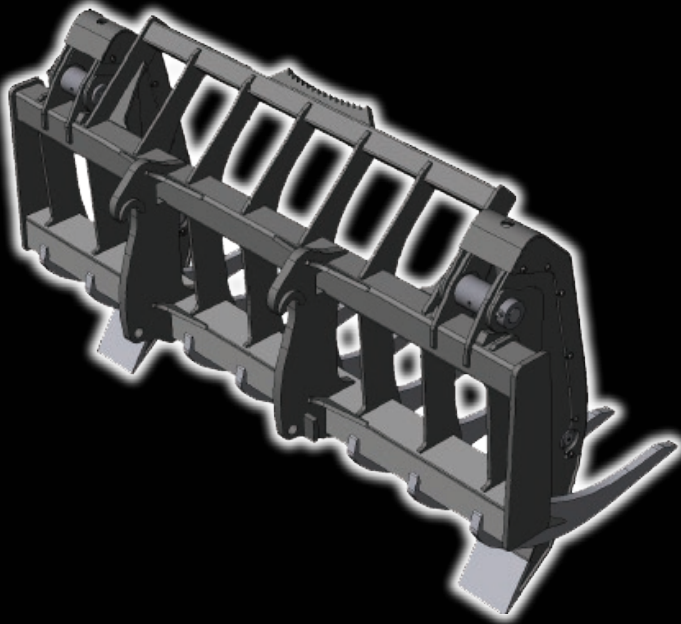

- Independent clamps provide improved uneven size load retention, load control and increased capacity.
- Loader Rakes are ideal for land clearing, tree stump/root removal, and loading wood waste material.
- Stacking Rakes offer a longer radius "C" shaped tine design for optimum stacking and material loading.
- Also works well in brush pile and storm demolition clean up applications.
- Tines spaced to sift debris for job clean up efficiency.
- Equipped with notched tree push bar to better grip tree while pushing it over.

Available in Quick Coupler and
Pin-On Style Mounting